



Part # 80-203

232 Branford Rd.
North Branford, CT 06471
Orders: 203.481.9460
Tech: 203.481.9943
Fax: 203.481.9641

Expansion Tank With Integrated Recovery Plumbing

This tank allows for a simplified way to plumb an expansion and recovery tank on the same vehicle. The integrated recovery means that you no longer need to run separate lines to an extra tank to catch overflow coolant.

Installation Notes

- When mounting, ensure that the tank necks are the highest point in the coolant system.
- This tank can be plumbed into the single bottom port (*shown to the right*) or can be run in-line by utilizing the second port on the expansion. (*shown on below*)
- If plumbed using single bottom port, the provided 1/2" NPT plug must be installed in the top port. Using teflon tape for all NPT fittings and plugs.

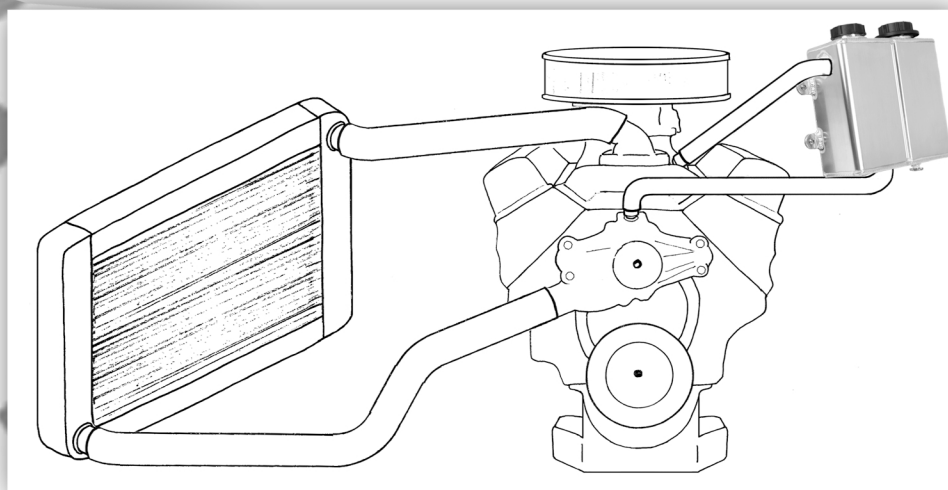
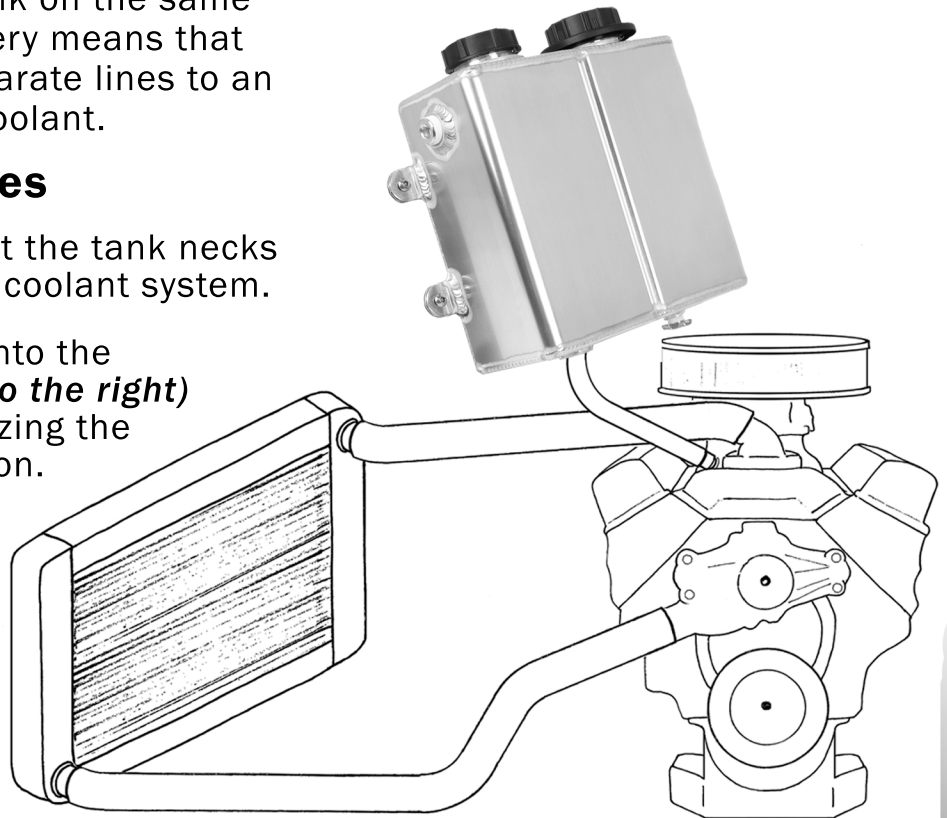

← Turn Over

www.CantonRacingProducts.com